

Product overview

plastic rolling bearings & components

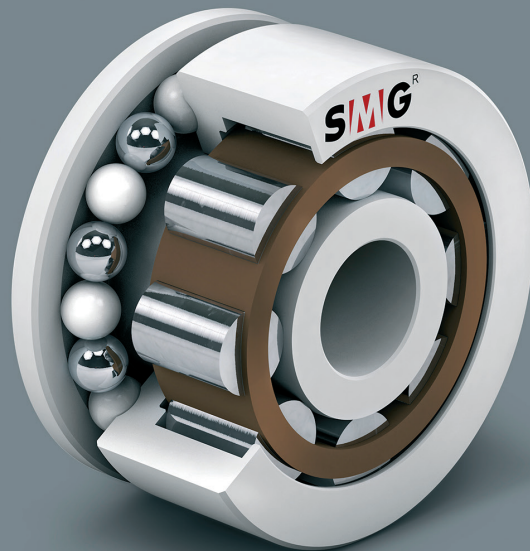

SMIG[®]

plastics technology

Content

Schmeing GmbH & Co. KG	page 3
Plastic product group – Product brand SMG	page 4

Technology

Materials.....	page 6
Resistance.....	page 7
Technology	page 8

Products

Properties of plastic rolling bearings	page 10
Applications.....	page 11-15
Customized products	page 16-21
Innovation.....	page 22-25
Standard products	page 26-35
Packaging.....	page 36

Technical Data

Dimensions and tolerances.....	page 37
Load and speed	page 38
Temperature influence	page 38

Contact

.....	page 39
-------	---------



Schmeing GmbH & Co. KG

SMG, brand of **Schmeing GmbH & Co. KG**, is part of the Groz-Beckert group.

Groz-Beckert is the world's leading provider of industrial machine needles, precision parts and fine tools, as well as systems and services for the production and joining of textile fabrics. All around the world, the products and services support the textile processes of knitting and warp knitting, weaving, felting, tufting, carding and sewing.

The company, founded in 1852, employs around 9,000 people and turned over about 618 million euro in 2020.

The site in Raesfeld has been continuously further developed and today has around 120 highly-qualified employees, who develop and produce future-oriented, market-ready, high-quality products for textiles and plastic technology.



Schmeing GmbH & Co. KG is certified for DIN EN ISO 9001.

The production site Raesfeld, Germany, is an important quality feature for SMG.

Whether available product or contracted service: State-of-the-art production technologies as well as testing and measuring equipment create ideal conditions.



Product brand SMG

The product brand SMG stands for **high quality articles out of plastics**.

The **core competence** lies in the design and manufacture of **customized** roller bearings and linear guidance systems for a wide range of applications.

The design of a ball bearing is based on its bearing position parameters like temperature, static/dynamic load, speed, chemicals, etc.), also taking into consideration technical, functional and economic aspects.

It is our goal to provide our customers with our products to give them the greatest possible benefit for optimum profitability.

Our strength lies in the production of **prototypes**, from a batch size of one piece up to **series production**. Our standard products can be found under **standard products (from page 26)**.

The product brand SMG promises high product **quality** through the machining production of our roller bearings.

Other parts of our expertise are milling and injection molding.





Technology

Materials	page 6
Resistance	page 7
Technology.....	page 8



Materials

Materials Races/Housing

- **POM*** *polyoxymethylene*
- **PP*** *polypropylene*
- **PE** *polyethylene*
- **PET** *polyethylene terephthalate*
- **PEEK** *polyetheretherketone*
- **PVDF** *polyvinylidene fluoride*
- **PPS** *polyphenylsulfid*
- **PI** *polyimide*

Materials Balls

- **Glass***
- **Borosilicate glass**
- **Stainless steel / AISI 316***
- **Stainless steel / AISI 420**
- **Brass**
- **Ceramics Si_3N_4**
- **Ceramics Al_2O_3**
- **Ceramics ZrO_2**
- **PP** *polypropylene*
- **PA 6.6** *polyamide 6.6*
- **POM** *polyoxymethylene*
- **PVDF** *polyvinylidene fluoride*

*standard materials



Materials Cages

- **PA 6.6*** *polyamide 6.6*
- **PP*** *polypropylene*
- **PE** *polyethylene*
- **PET** *polyethylene terephthalate*
- **PEEK** *polyetheretherketone*
- **PVDF** *polyvinylidene fluoride*
- **PPS** *polyphenylsulfid*
- **PTFE** *polytetraflouethylene*
- **PI** *polyimide*
- **Full ball design, without cage**

Materials support balls

- **PA 6.6*** *polyamide 6.6*
- **Stainless steel / AISI 316***
- **Ceramics Si_3N_4**
- **Ceramics Al_2O_3**
- **Ceramics ZrO_2**
- **POM** *polyoxymethylene*
- **PP** *polypropylene*
- **PVDF** *polyvinylidene fluoride*
- **PUR** *polyurethane*



Resistance

The selection of a suitable material according to the respective application is decisive for an optimum function of the machine element (rolling bearing/ linear guide).

Plastics have different mechanical and chemical properties, which are due to the chemical structure of the respective plastic.

In the field of plastics, a basic distinction is made between thermoplastics, thermosets and elastomers. **Thermoplastics are mainly used in the manufacture of plastic ball bearings.**

The property profile of a plastic is described in the data sheet/safety data sheet of the respective manufacturer. There, information is given on the bulk density, mechanical properties such as tensile strength, elongation at break, modulus of elasticity, etc., electrical, thermal and optical properties, as well as information on the water absorption of a material

(hydrophilic / hydrophobic materials). The property profile of the used plastic is transferred to the prefabricated part.

In addition to the property profile of a plastic, **resistance** also needs to be considered. Resistance includes resistance to a wide variety of media (liquid), temperature resistance, resistance to radiation, etc.

Internationally recognised databases, for plastic parameters, can be used to determine the suitable plastic for each requirement profile. They provide guidelines. The long-term properties in the application area must be considered on a case-by-case analysis.

We shall be pleased to advise you on the selection of a suitable plastic!



Technology

Turning

Production facilities on latest CNC turning centers equipped with automatic bar stock feed up to a diameter of 78 mm. The maximum collet capacity amounts to 280 mm – available from single-piece to large-scale production.

Milling

SMG has specialized in the manufacture of small parts made of high performance materials at the highest degree of accuracy and precision – available from single-piece to large-scale production.

Injection moulding

Almost all thermoplastics are processed: PP, PA, POM, PMMA, PUR, ... with or without additives like carbon fiber, glass fiber, graphite, MOS2. Also high-capacity plastics such as PPS and PEEK are used for our moulded parts.

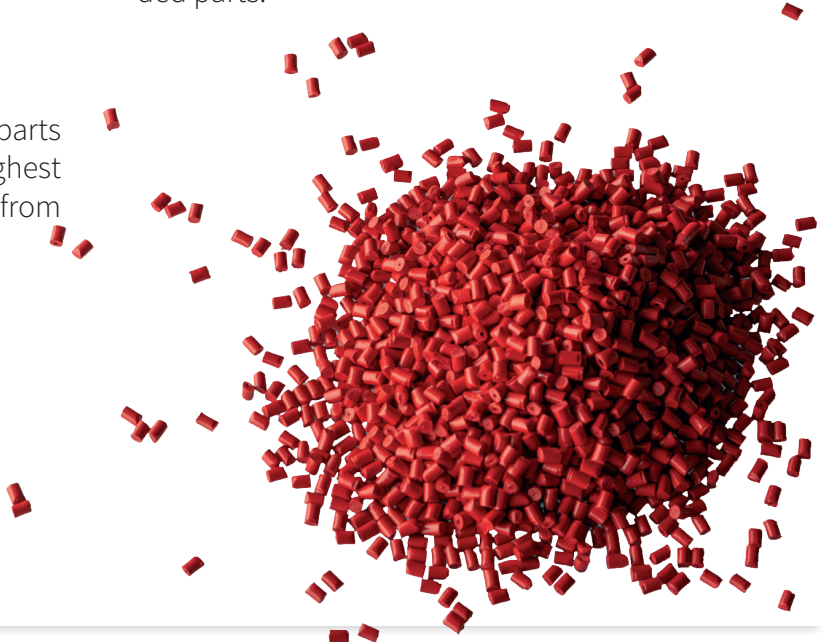

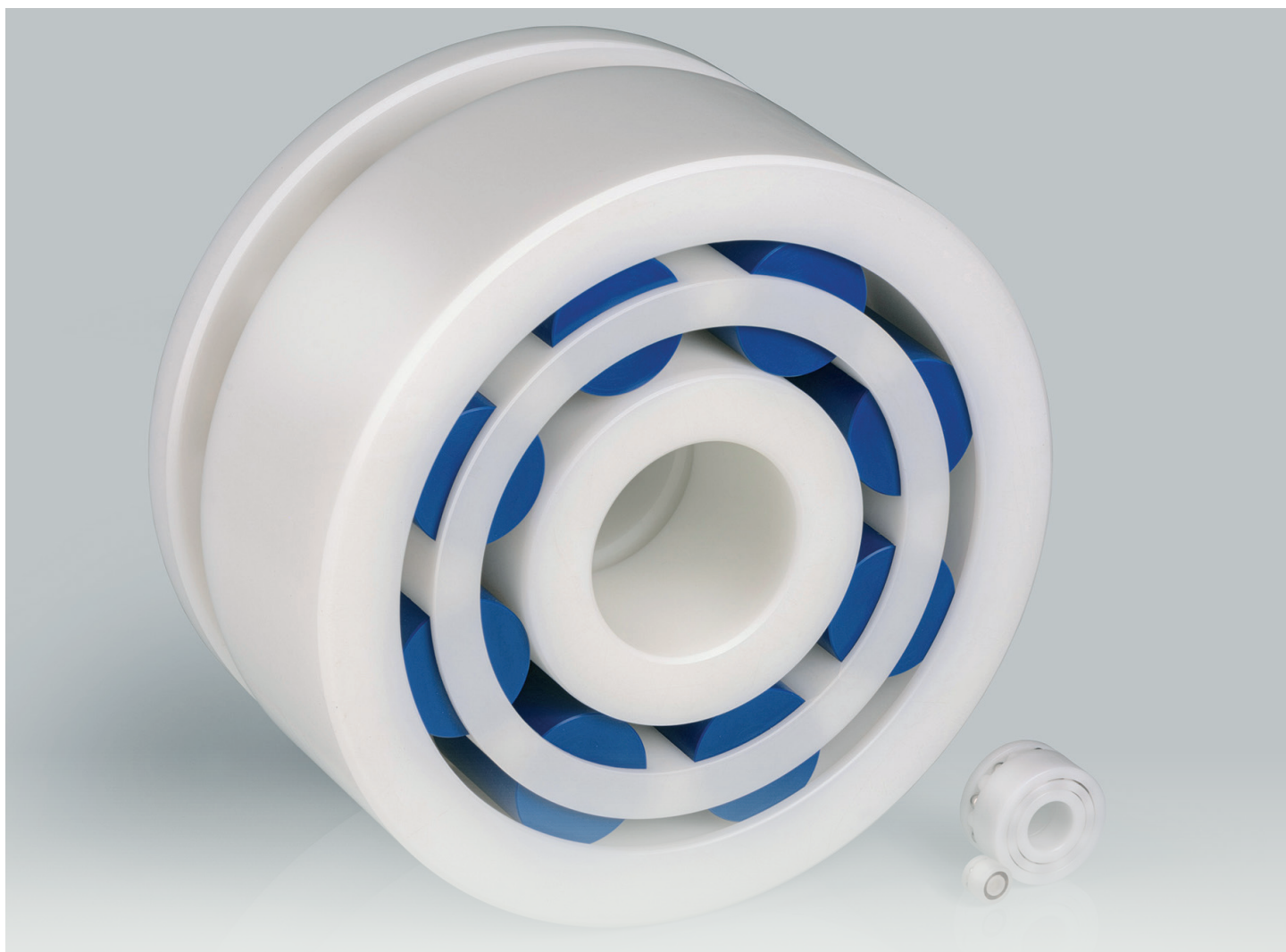

Products

Properties of plastic rolling bearings.....	page 10
Applications.....	page 11-15
Customized products.....	page 16-21
Innovation.....	page 22-25
Standard products.....	page 26-35
Packaging.....	page 36

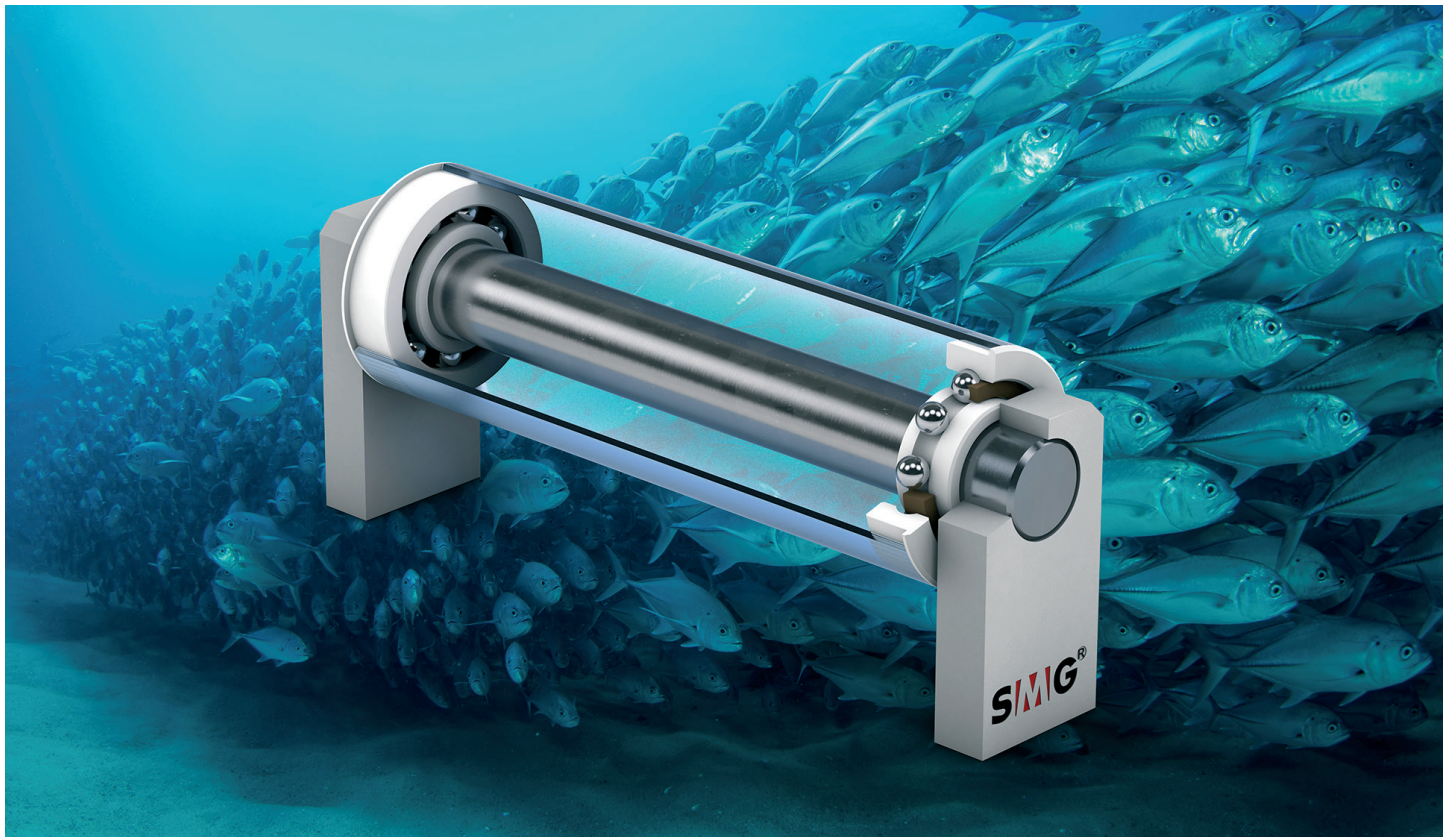

Properties of plastic rolling bearings

- run **lubrication- and maintenance-free** (dry-running)
- have **little or no magnetism**
- can be designed to be **electrically insulating or electrically conductive** as required
- have a **high specific strength**
 - **weight reduction** of up to 80 % compared to steel
 - **vacuum and pressure suitable**
 - **high wear and fatigue resistance**
- have a **low coefficient of friction** and therefore a **low starting torque**
- have **high resistance to acids and alkalis** (chemical structure)
- made of high performance plastics (PEEK/PI...) are **temperature resistant up to more than 250 °C**
- have a **low creep tendency** and thus a **high dimensional accuracy** over the entire service life
- are **free of metallic components** depending on the version
- are **conditionally loadable**, the stat. / dyn. load / speed below steel bearings

Application



Built-in transport roller for feeding pipe material into a processing plant. The system is operated at room temperature using cooling lubricant.

	CUSTOMER REQUEST	DESIGN
Material	Design by SMG	ring of POM, cage of PA, balls of stainless steel 1.4401
Speed	50 rpm	max. 1.850 rpm
Basic load rating stat./dyn.	50 N / 50 N	max. 108 N / max. 162 N
Operating temperature	Room temperature	-40 - +90 °C
Chemical additives	Water-based cooling lubricant	resistant



Ball bearings with integrated gear wheel and belt pulley for transmitting drive forces to a conveyor section in the galvanic industry.

Hydrochloric acid is used in electroplating. The system is operated in a temperature range of up to 50°C

	CUSTOMER REQUEST	DESIGN
Material	Design by SMG	rings of PP, cages of PP, balls of glass
Speed	30 rpm	max. 1.650 rpm
Basic load rating stat./dyn.	3 N / 3 N	max. 198 N / max. 288 N
Operating temperature	20 - 50°C	-50 - +80°C
Chemical additives	hydrochloric acid	resistant



Printing industry

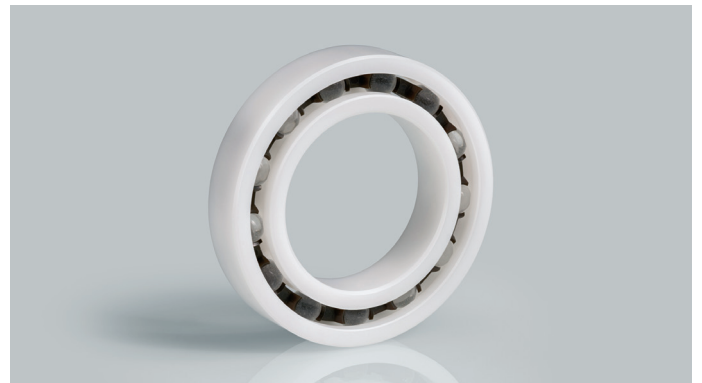

Ball bearing for use in a steel ring for guiding paper webs in printing machines. The system is operated at room temperature. Low starting torque required.

	CUSTOMER REQUEST	DESIGN
Material	POM	rings of POM, cages of PA, balls of glass
Speed	1.000 rpm	max. 2.200 rpm
Basic load rating stat./dyn.	5 N / 5 N	max. 55 N / max. 80 N
Operating temperature	Room temperature	-40 - +90 °C



Water technologies

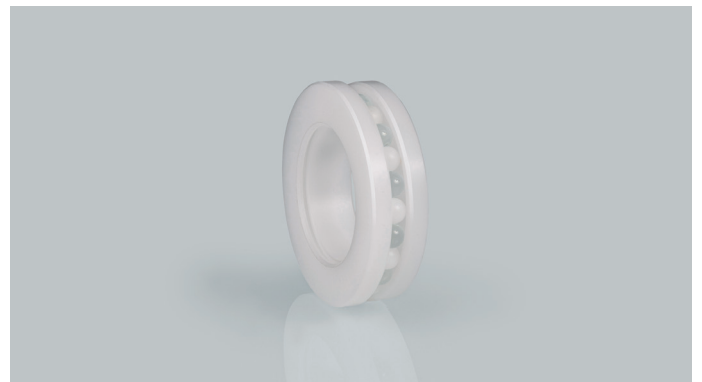

Axial bearing for supporting a rotating fountain figure. Operation of the well in various weather conditions. Contact of the ball bearing with water.

	CUSTOMER REQUEST	DESIGN
Material	Standard axial bearing	ring of POM, balls of glass alternating with POM
Speed	50 rpm	max. 365 rpm
Basic load rating stat./dyn.	50 N / 50 N	max. 870 N / max. 1.090 N
Operating temperature	0 - 45 °C	-40 - +90 °C
Chemical additives	Water	resistant



Ball transfer unit for safe transport of horizontal glass panes.
Protection against breakage and scatching during manual feeding into a processing unit.

	CUSTOMER REQUEST	DESIGN
Material	smooth, soft surface of the support ball	housing of POM, support ball of PUR
Basic load rating stat.	50 N	max. 70 N
Operating temperature	Room temperature	-40 - +90 °C



Drive and conveyor roller with integrated gear wheel and **Z-discs** for driving round belts.
Used for transporting food. The plant is operated in an air-conditioned production facility.

	CUSTOMER REQUEST	DESIGN
Material	Basic material food grade	rings and Z-discs of POM, cage of PP balls of stainless steel 1.4401
Speed	100 rpm	max. 2.000 rpm
Basic load rating stat./dyn.	100 N / 150 N	max. 180 N / max. 252 N (4-row)
Operating temperature	1 - 8 °C	-40 - +90 °C

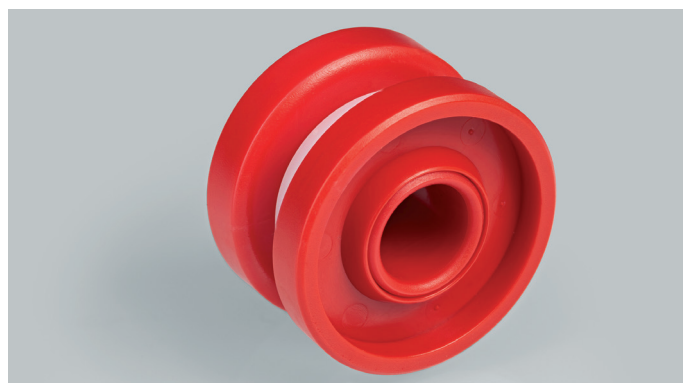

Radial bearing with integrated RFID chip for use in an intralogistics system. The radial bearings is guided in a C-rail. Storage, administration and picking of textiles. Use at room temperature.

	CUSTOMER REQUEST	DESIGN
Material	Design by SMG	rings of POM, cages of PA, balls of stainless steal 1.4034
Speed	300 rpm	max. 2.200 rpm
Basic load rating stat./dyn.	35 N / 40 N	max. 55 N / max. 80 N
Operating temperature	Room temperature	-40 - +90 °C



Radial bearings for Circulation of yarns and textile surfaces.

	CUSTOMER REQUEST	DESIGN
Material	Design by SMG	rings of POM, cages of PA, balls of stainless steal 1.4401
Speed	1.600 rpm	max. 2.050 rpm
Basic load rating stat./dyn.	5 N / 40 N	max. 60 N / max. 90 N
Operating temperature	18 - 45°C	-40 - +90 °C



Packing industry



Cam roller for the deflection of cartons on conveyor lines.
 Avoid damage to the packaging during deflection.
 Use in a wide range of temperature ranges, depending on the industry.

	CUSTOMER REQUEST	DESIGN
Material	Standard Guide roller	rings of POM, cages of PA, balls of Niro 1.4401
Speed	900 rpm	max. 1.200 rpm
Basic load rating stat./dyn.	200 N / 200 N	max. 306 N / max. 450 N
Operating temperature	0 - 45°C	-40 - +90 °C



Electronic Industry

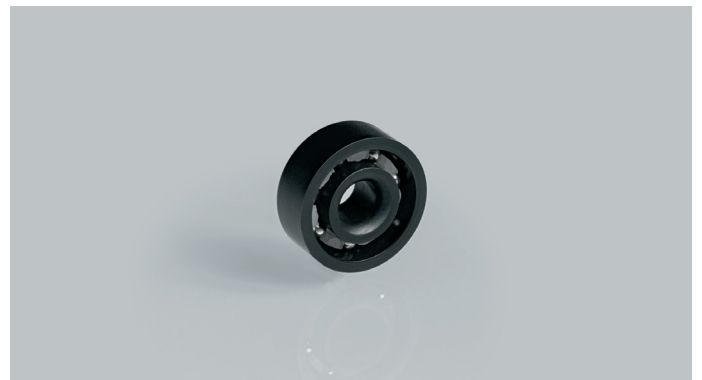

Radial ball bearing for the bearing of an electric motor in a hand blender.
 Use in private households at room temperature.

	CUSTOMER REQUEST	DESIGN
Material	Design by SMG	ring of POM black, cage of PA, balls of Niro 1.4401
Speed	3.000 rpm	max. 4.500 rpm
Basic load rating stat./dyn.	10 N / 15 N	max. 30 N / max. 45 N
Operating temperature	Room temperature	-40 - +90 °C

Customized products

These ball bearings are manufactured by customers specifications. Please see our product template on our website www.smg-plastics.de under the **category Download**.



Cylindrical roller bearings

The cylindrical roller bearing consist of an outer and inner ring and a cage, like a radial bearing. Instead of balls, cylindrical rollers are used as rolling elements, which have the advantage that they **can absorb higher radial forces**.

They are available in NU, NJ, NUP and N versions.

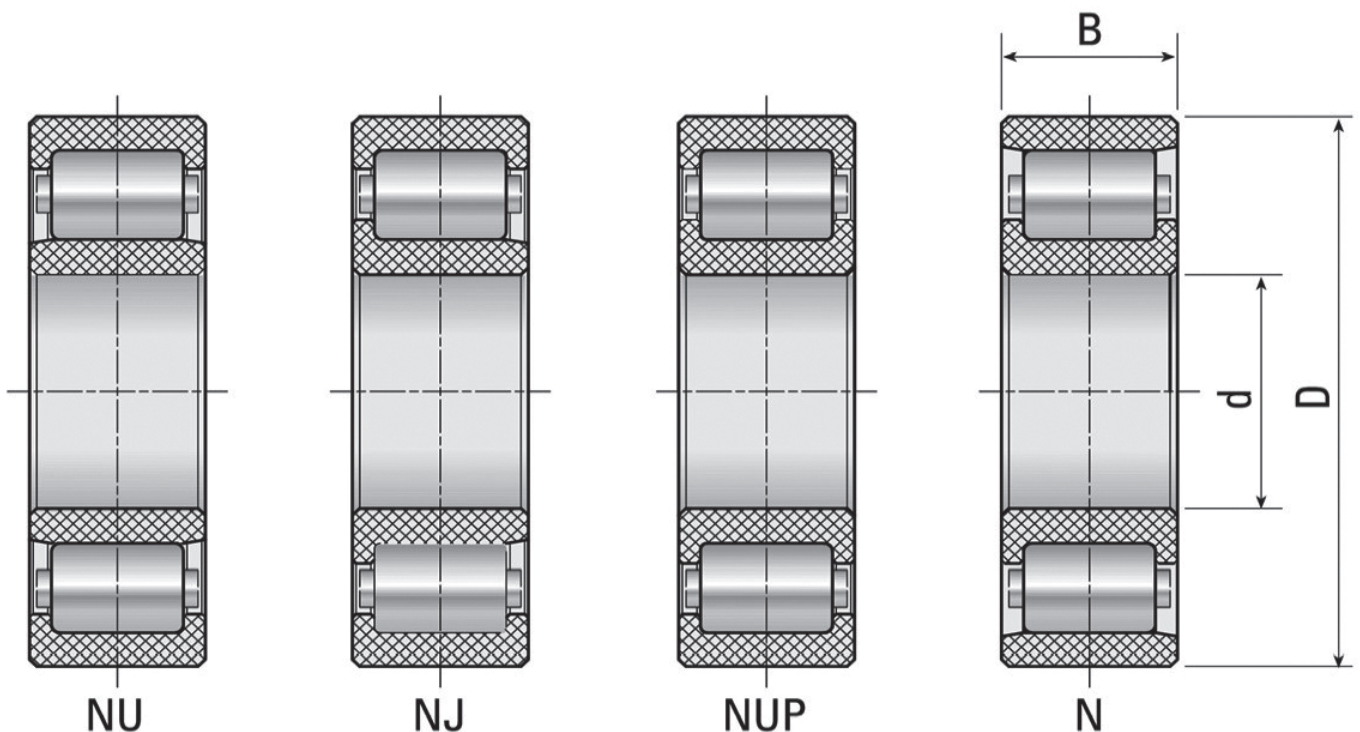

The linear expansion of the shaft can be compensated by displacement of the rings (exception: NUP version).

Like all other plastic bearing designs, cylindrical roller bearings have lubrication-free dry running.



Spherical roller bearing

The spherical roller bearing has **two rows of balls**. The outer ring is equipped with spherical raceway, the inner ring has a raceway with cylindrical or tapered bore. It's **self-retaining**.

The main task of the spherical roller bearing is the transmission of radial/thrust forces while simultaneously compensating for angular shaft misalignments and misalignment of up to 4° misalignment.

Spherical roller bearings are used, **for example, in conveyor systems**.

Spherical roller bearings, like all other plastic bearing designs, have **lubrication-free dry running**.

These ball bearings are manufactured to customer specifications.

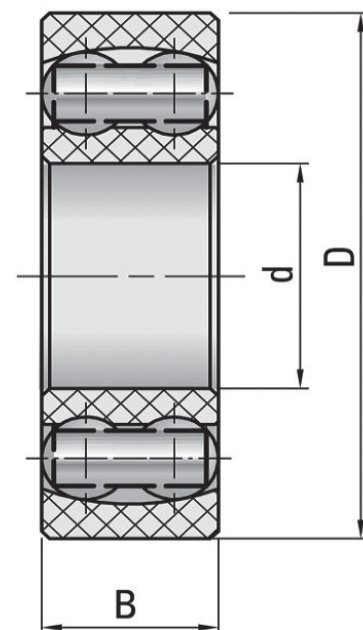

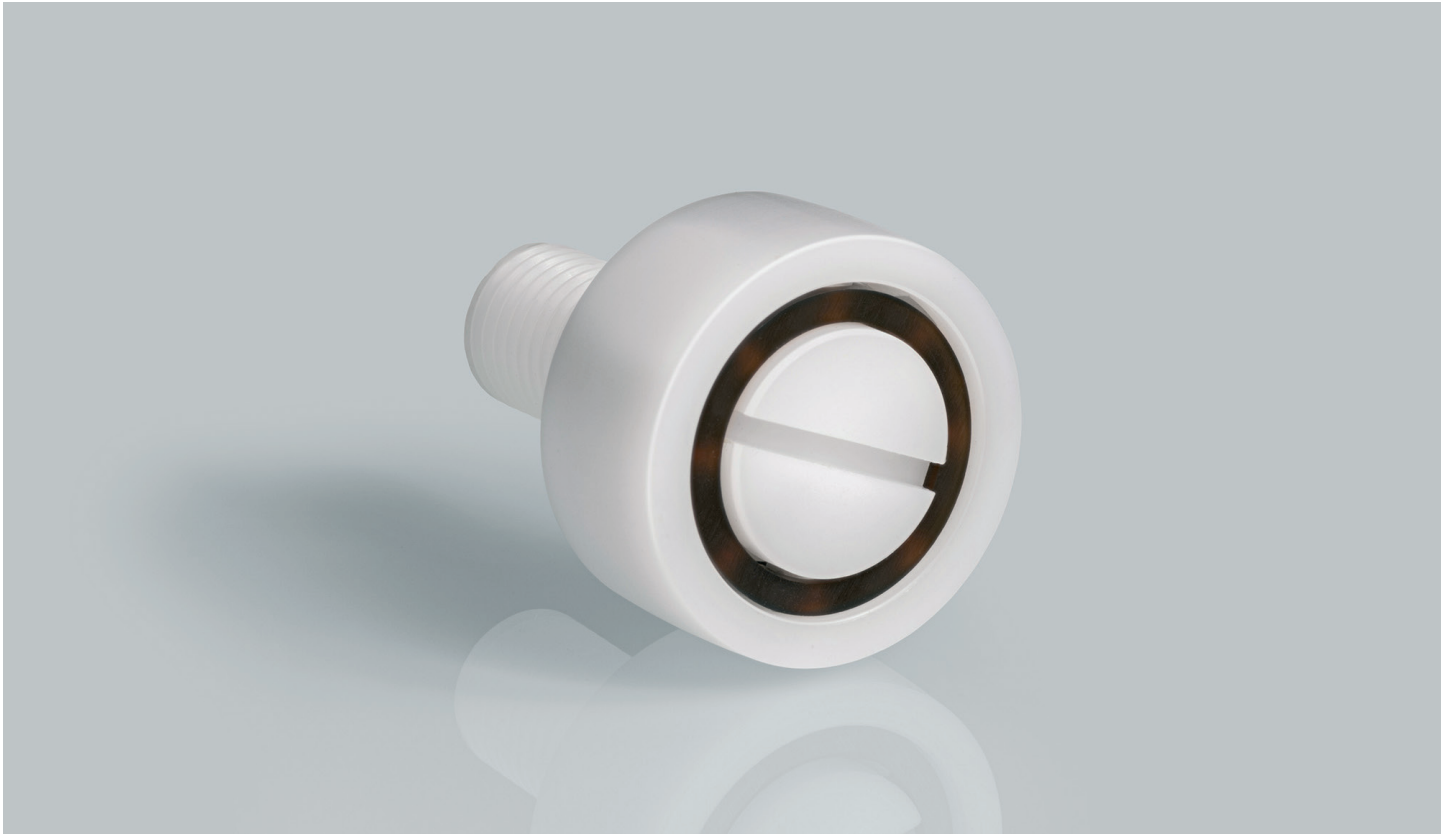

Pulleys

Pulleys can be designed in a wide variety of variants, whether single-row, double-row or multi-row, with groove and keyway, with smooth outer surface, crowned etc.

The materials used can be selected according to the requirements of the application.

Application example:

Deflection pulleys for flat and round belts for a wide variety of transport systems.



Advantages:

Creation of added value through integrative solutions and thus a simplified construction of the plant. Use of application-specific materials, good chemical resistance, optimized service life and cost savings.

Pulleys have the advantage of improved lateral guidance in conveyor technology.

For example, they can be used without lubrication even in humid atmospheres or under steam. Even suitable for use in the high temperature range up to 250°C when using high-performance plastics. If food-compatible materials are used, they can also be used in the food industry.

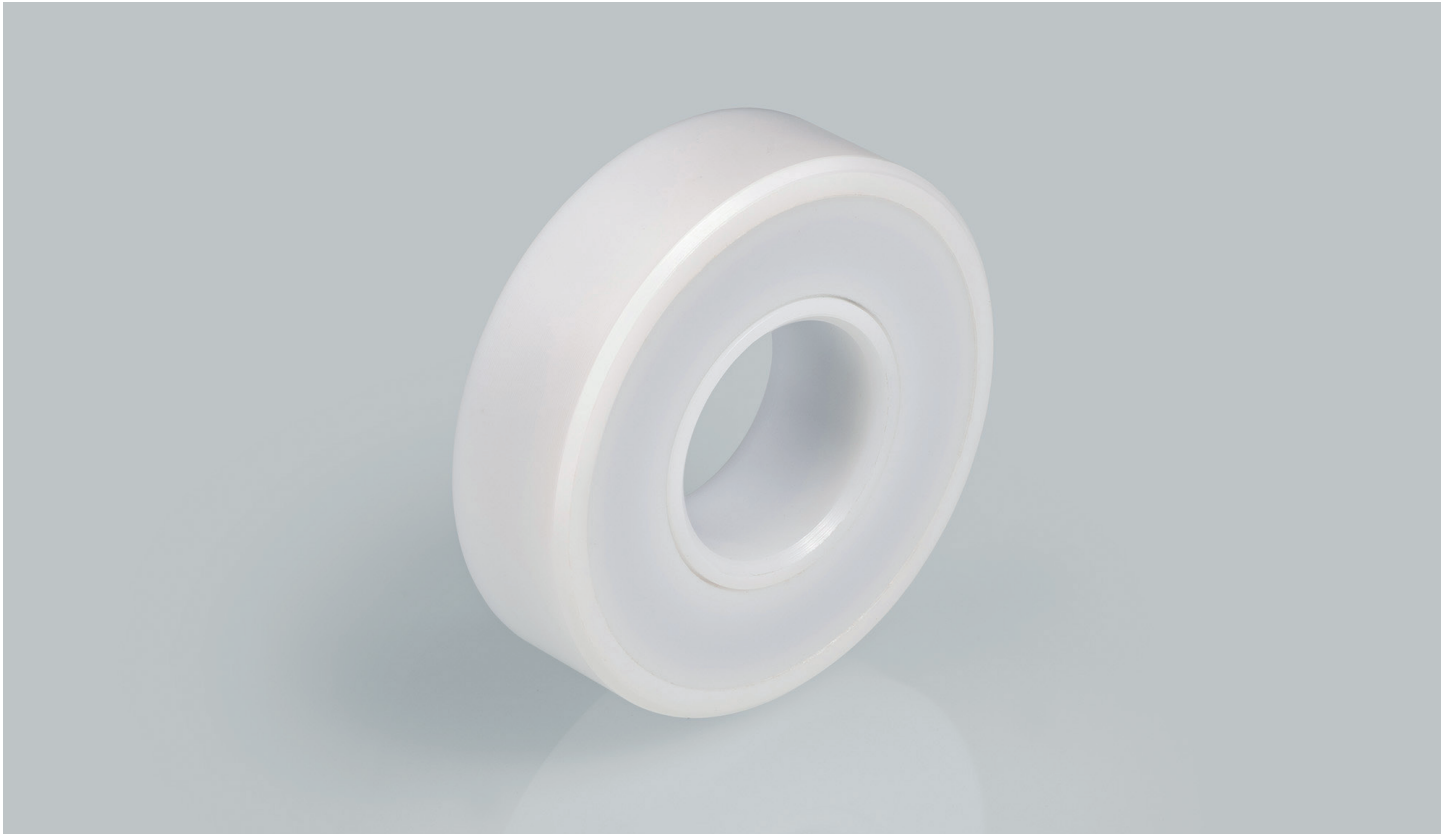

Ball bearings with Z-shields

Z-shields are used to cover ball bearings. Depending on requirements, plastic ball bearings can be covered on one or both sides. In contrast to steel ball bearings, sealing is not necessary in most cases, as the plastic ball bearing is used without lubrication.

The integration of Z-shields prevents the penetration of coarse dirt particles into the bearing. Dirt particles can impair the running properties of the ball bearing and lead to increased wear.

Z-shields are integrated into SMG plastic ball bearings by inserting a groove in the outer ring.

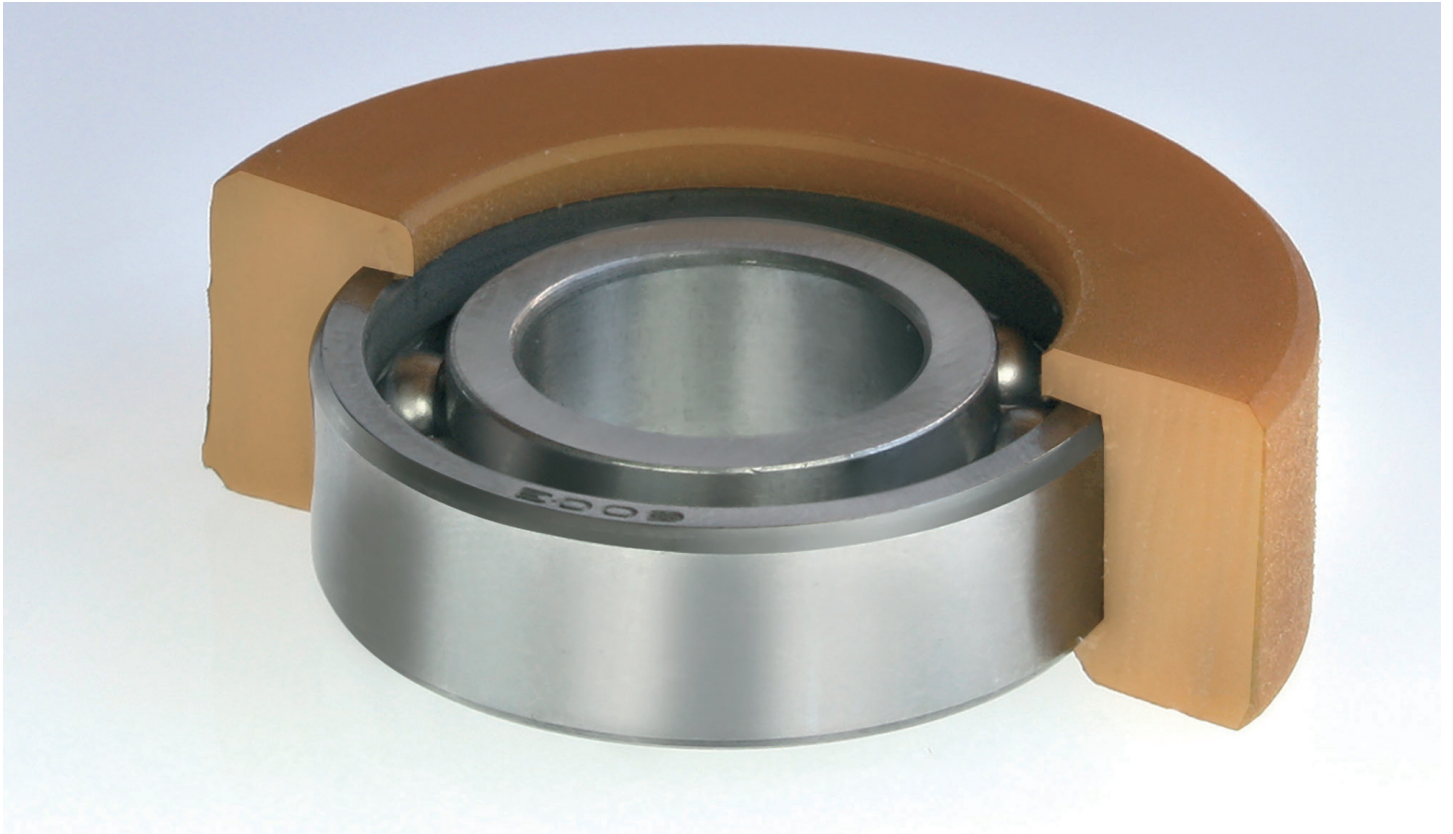

Covering

Coverings of SMG available **in almost all dimensions and various material combinations** POM/PP/PET/PEEK etc. They are designed and manufactured to customer specifications.

SMG offers coverings for steel ball bearings. Bandages from SMG have a smooth surface and are therefore suitable for the transport of sensitive surfaces such as glass, ceramics, etc. . The running noise of steel bearings can be reduced by using plastic coverings.

By using steel bearings, they can be used in applications with high loads.

Steel bearings are usually provided by the customer.

SMG also offers covering plastic ball bearings. Certain applications require a precise deflection, with specific running characteristics for the material to be conveyed, for example to form precise layers of materials.

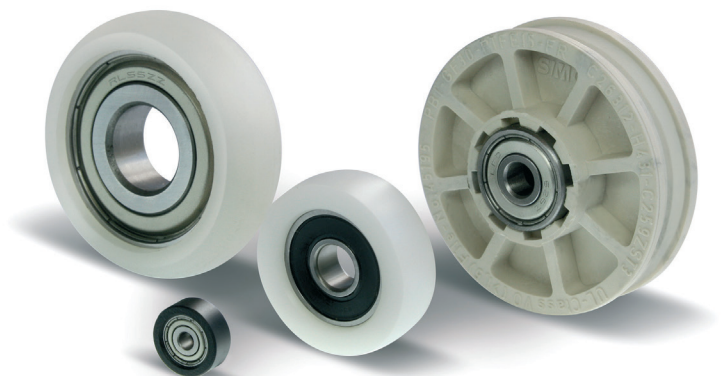



Special ball bearing

Special ball bearings differ from the standard portfolio in their dimensions, geometries and materials and **are manufactured to customer specifications in accordance with the respective application:**

- Deviation from standard inner and/or outer ring dimensions, such as a wider inner ring than outer ring, or deviations in diameter.
- Integration of peripheral components into the outer ring possible, e.g. attachment of a toothing
- Integration of further components, for example an RFID chip
- Design of two-row and multi-row ball bearings to increase static/dyn. load carrying capacity
- Use of plastics with appropriate additives, for example to increase UV resistance
- Use of high-performance plastics, such as polyetheretherketone (PEEK) or polyimide (PI), for example for use in a higher temperature range
- Selection of the appropriate plastic and other ball bearing components, e. g. for use in a radiation area

Innovation

Axial and radial ball bearing

The axial-radial ball bearing can support axial and radial forces simultaneously.

It has a **high load capacity and runs maintenance and lubrication-free**. The ball bearing is **resistant to acids and alkalis** and has a low coefficient of friction.

If high-performance plastics are selected, such as PEEK, the axial-radial ball bearing can be used in temperature ranges up to over 200°C. The axial-radial ball bearing can be used for a wide range of applications. Due to the space-saving design resulting from the combination of both bearings (axial and radial bearings), the bearing is suitable even for limited installation conditions at bearing positions.



Due to the free design possibilities of the axial-radial ball bearings, they can be designed customer-specific or application-specific. For example, the requirement of increased load absorption can be realized by using cylindrical rollers in the radial area of the bearing.

Axial-radial ball bearings from SMG are **up to 70 percent lighter** than comparable steel ball bearings.

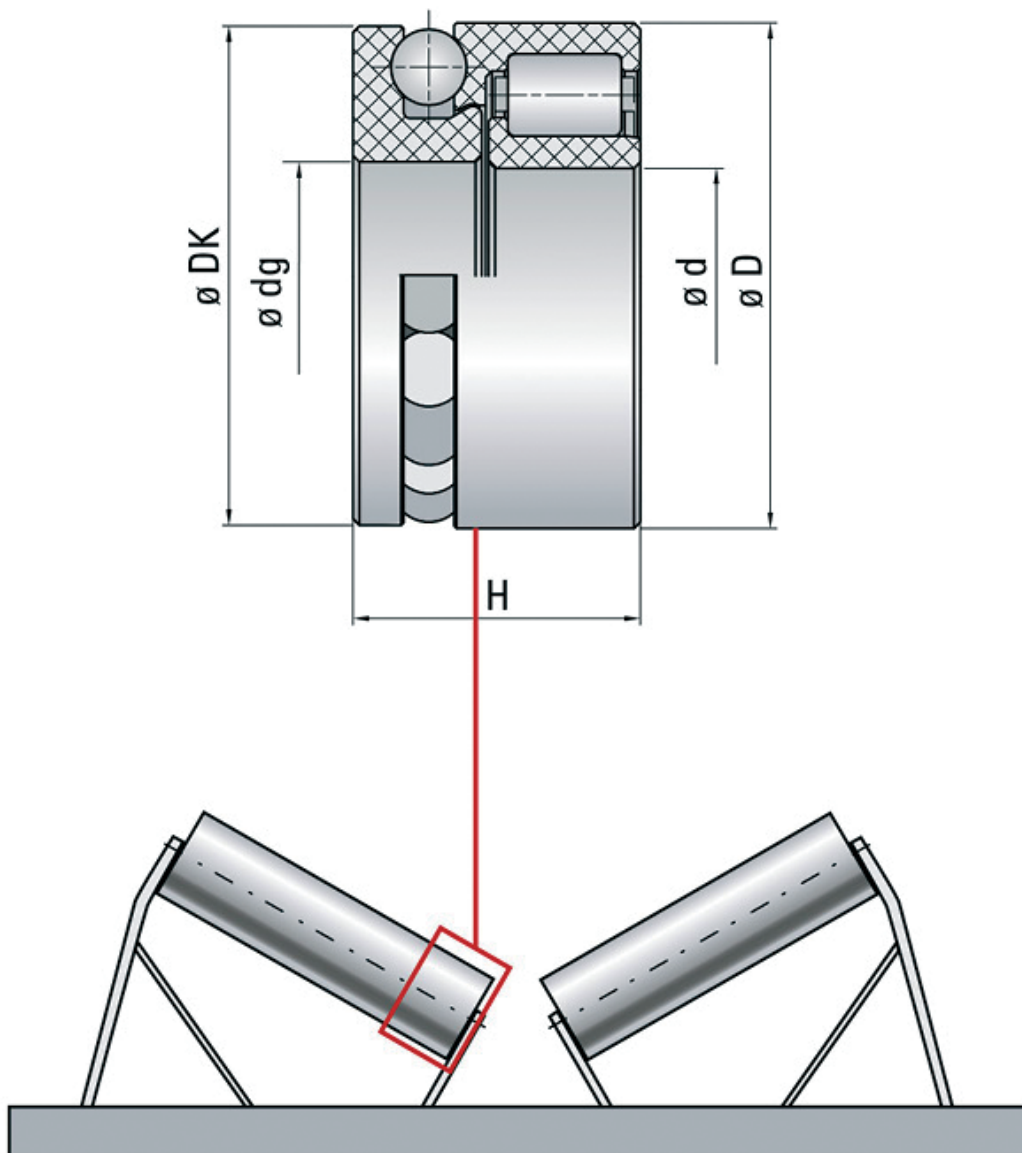

Linear guide

Linear guides **out of plastics** have a **very low weight** in comparison to linear guides out of steel. Low kinetic energy due to the use of plastic.

Depending on the plastic material which is used linear guides can be used **in a temperature range -200 °C - +250 °C**. Furthermore the plastic linear guides can be produced according the chemicals (acid + lye), which are used in the necessary application.

The plastic linear guides can be used in a medium, because the depositories are **lubrication-free**.

The plastic linear guides are customized products and **can be produced in small quantities**.

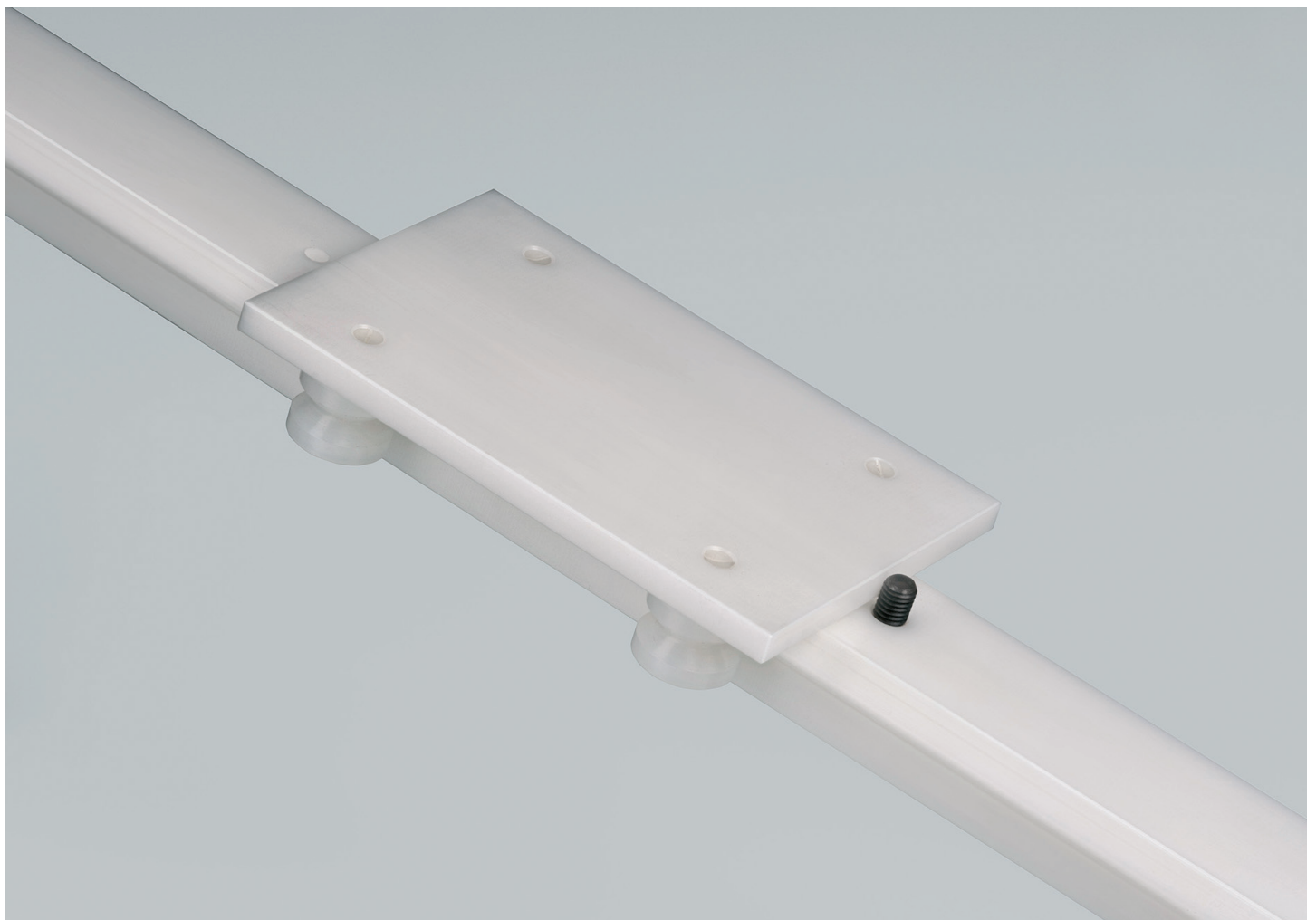
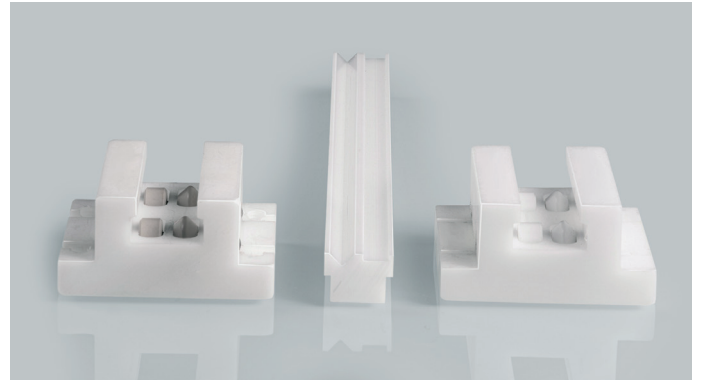

■ **Type 1**

It has **precise running properties** and is **adjustable by the eccentric**. It can be installed overhead. It has a low rolling friction.

■ **Type 1 K**

Has the same basic properties as Type 1. The special feature is that with Type 1 K **cornering** is possible. As a result, the construction of a transport system with multiple processing stations is possible.

■ **Type 2**

It has good running properties. In comparison to type 1 and 3 **higher speeds** are reachable. It is a solid construction. This type of plastic linear guides has a low rolling friction.

■ **Type 3**

It works with **sliding and rolling friction**. It has a compact structural shape.

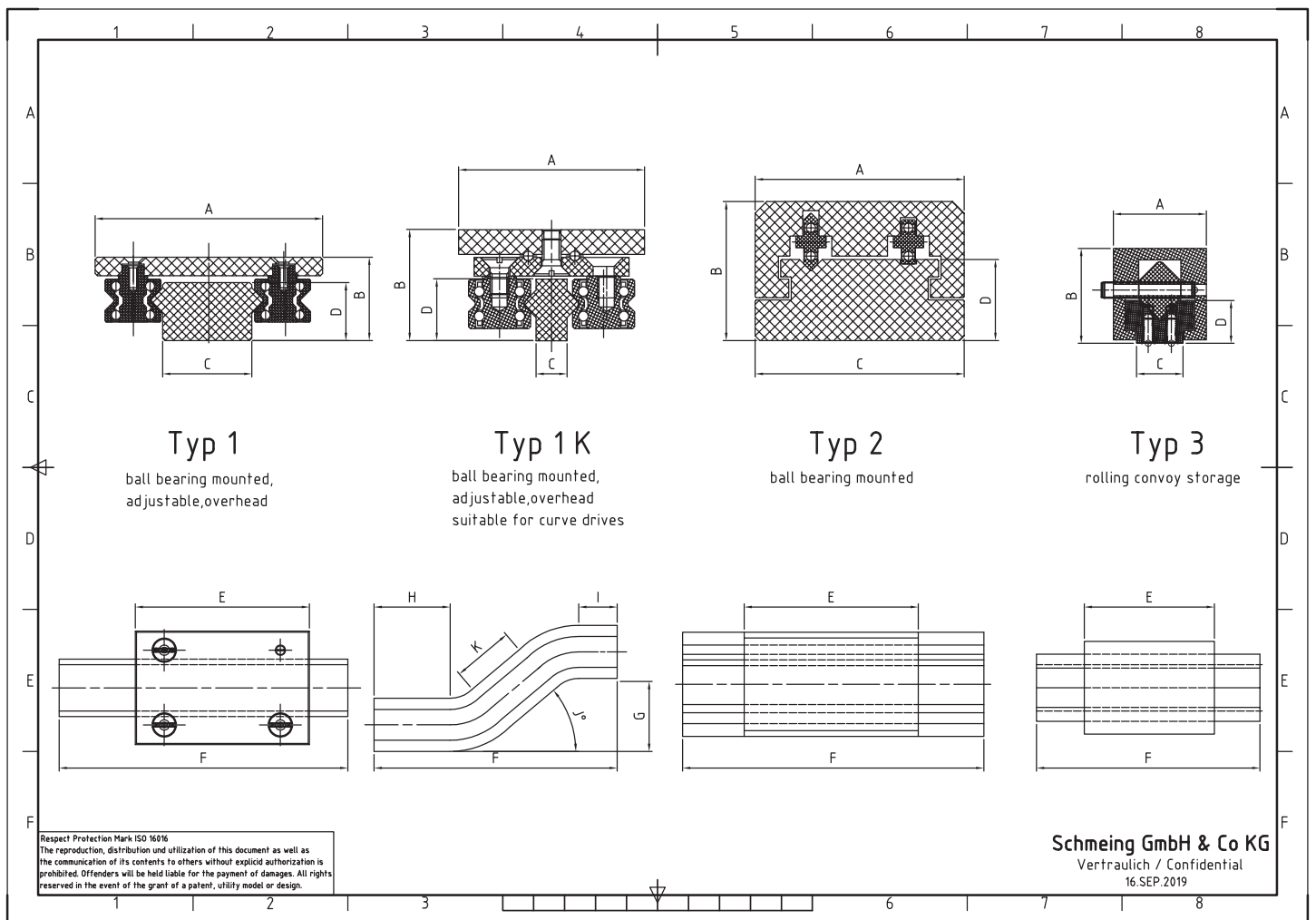

Standard products

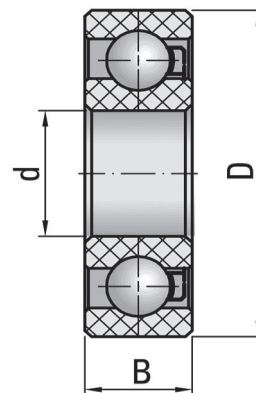
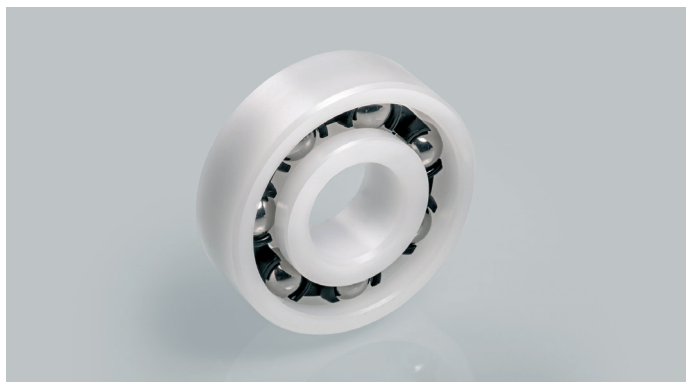

Radial bearing

Radial bearings consist of an outer and inner ring, a cage and balls. The bearings are self-retaining.

They are used in a wide variety of applications.

Their main task is the transmission of radial forces.

By their raceway geometry, they can also absorb and transmit a small axial force. Due to their low frictional torque they are **ideal for higher speeds**.

Standard radial bearings by SMG have the **material combinations:**

	rings	cage	balls
■	POM	PA	AISI 316
■	POM	PA	Glass
■	PP	PP	AISI 316
■	PP	PP	Glass

Radial bearings in SMG’s standard portfolio are designed on the basis of DIN 625, with the exception of edge distances. Single row radial bearings are included in the standard portfolio. Double row radial bearings, as well as radial bearings with Z-shields can be found under **customized products (from page 16)**.

Product table inch bearings

TYPE	d		D		B		Basic load rating		max. speed n (rpm)	rings: POM		cage: PA	
	(inch)	(mm)	(inch)	(mm)	(inch)	(mm)	stat (N)	dyn (N)		SMG part no. balls: 1.4401	weight (g)	SMG part no. balls: Glass	weight (g)
R4	1/4"	6,35	5/8"	15,88	0,196"	4,98	40	60	3.600	464.040	1,2	465.040	0,9
R6	3/8"	9,53	7/8"	22,22	7/32"	5,56	60	80	2.200	464.060	3,3	465.060	2,1
R8	1/2"	12,7	1-1/8"	28,58	1/4"	6,35	110	160	1.750	464.080	6,3	465.080	3,9
R10	5/8"	15,88	1-3/8"	34,93	9/32"	7,14	170	250	1.400	464.090	9,0	465.090	5,9
R12	3/4"	19,05	1-5/8"	41,28	5/16"	7,94	200	300	1.200	464.120	16,6	465.120	10,1
R16	1"	25,4	2"	50,8	1/2"	12,7	240	360	1.050	464.160	29,5	465.160	22,1

Product table radial bearing

TYPE							rings: POM		cage: PA		rings: PP		cage: PP	
	d (mm)	D (mm)	B (mm)	Basic load rating		max. speed n (rpm)	SMG part no. balls: 1.4401	weight (g)	SMG part no. balls: Glass	weight (g)	SMG part no. balls: 1.4401	weight (g)	SMG part no. balls: Glass	weight (g)
				stat (N)	dyn (N)									
623	3	10	4	30	45	4.500	464.623	0,4	465.623	0,3	470.623	0,4	468.623	0,2
624	4	13	5	40	60	3.600	464.624	0,9	465.624	0,7	470.624	0,5	468.624	0,5
625	5	16	5	45	65	3.050	464.625	1,4	465.625	1,0	470.625	1,3	468.625	0,8
626	6	19	6	50	70	2.600	464.626	2,8	465.626	1,8	470.626	2,4	468.626	1,4
607	7	19	6	50	70	2.600	464.607	2,2	465.607	1,5	470.607	1,7	468.607	1,1
627	7	22	7	55	80	2.200	464.627	3,9	465.627	2,6	470.627	3,2	468.627	1,9
608	8	22	7	55	80	2.200	464.608	3,6	465.608	2,4	470.608	3,0	468.608	1,8
609	9	24	7	60	90	2.050	464.609	7,8	465.609	6,6	470.609	5,7	468.609	4,5
629	9	26	8	70	100	1.900	464.629	6,3	465.629	4,1	470.629	5,2	468.629	3,9
6000	10	26	8	90	130	1.900	464.100	6,2	465.100	4,1	470.100	5,1	468.100	3,0
6200	10	30	9	110	160	1.650	464.200	8,9	465.200	6,5	470.200	7,1	468.200	4,7
6300	10	35	11	190	280	1.400	464.300	17,4	465.300	11,3	470.300	14,5	468.300	8,4
6001	12	28	8	110	160	1.750	464.101	7,1	465.101	4,6	470.101	5,9	468.101	3,5
6201	12	32	10	150	220	1.550	464.201	11,9	465.201	7,7	470.201	9,9	468.201	5,7
6301	12	37	12	210	310	1.300	464.301	21,8	465.301	13,4	470.301	18,6	468.301	10,2
16002	15	32	8	130	190	1.500	464.002	8,0	465.002	5,5	470.002	6,5	468.002	4,1
6002	15	32	9	140	200	1.500	464.102	9,1	465.102	6,4	470.102	7,4	468.102	4,7
6202	15	35	11	170	250	1.400	464.202	14,3	465.202	9,4	470.202	11,8	468.202	7,0
6302	15	42	13	260	370	1.200	464.302	27,3	465.302	17,5	470.302	23,0	468.302	13,2
16003	17	35	8	160	240	1.400	464.003	9,6	465.003	6,6	470.003	7,9	468.003	4,9
6003	17	35	10	170	260	1.400	464.103	11,4	465.103	8,4	470.103	9,0	468.103	6,0
6203	17	40	12	220	260	1.250	464.203	19,1	465.203	13,9	470.203	15,4	468.203	10,2
6303	17	47	14	260	370	1.050	464.303	37,5	465.303	24,5	470.303	31,3	468.303	18,2
16004	20	42	8	190	290	1.150	464.004	13,8	465.004	9,8	470.004	10,5	468.004	7,0
6004	20	42	12	200	300	1.150	464.104	20,7	465.104	14,2	470.104	16,8	468.104	10,9
6204	20	47	14	270	420	1.050	464.204	33,4	465.204	22,1	470.204	27,6	468.204	16,4
6304	20	52	15	350	500	950	464.304	48,6	465.304	31,7	470.304	40,5	468.304	23,6
16005	25	47	8	210	310	1.050	464.005	19,1	465.005	10,9	470.005	16,2	468.005	9,0
6005	25	47	12	240	360	1.050	464.105	23,8	465.105	16,6	470.105	19,3	468.105	12,1
6205	25	52	15	320	480	950	464.205	39,6	465.205	27,0	470.205	32,5	468.205	26,6
6305	25	62	17	400	600	725	464.305	76,4	465.305	49,5	470.305	63,9	468.305	36,9
16006	30	55	9	240	370	900	464.006	26,2	465.006	17,3	470.006	21,6	468.006	13,0
6006	30	55	13	280	420	900	464.106	35,4	465.106	24,2	470.106	28,9	468.106	17,7
6206	30	62	16	360	550	800	464.206	63,4	465.206	41,6	470.206	52,6	468.206	30,8
6306	30	72	19	460	700	675	464.306	113,8	465.306	72,0	470.306	95,7	468.306	53,9
16007	35	62	9	270	410	800	464.007	32,3	465.007	21,8	470.007	26,3	468.007	16,3
6007	35	62	14	320	480	800	464.107	47,4	465.107	32,0	470.107	38,9	468.107	23,5
6207	35	72	17	410	620	700	464.207	94,9	465.207	60,3	470.207	79,8	468.207	45,2
6307	35	80	21	490	750	600	464.307	153,7	465.307	98,7	470.307	129,6	468.307	74,4
16008	40	68	9	300	450	750	464.008	37,7	465.008	29,3	470.008	30,6	468.008	19,2
6008	40	68	15	350	520	750	464.108	52,3	465.108	39,4	470.108	45,5	468.108	28,7
6208	40	80	18	440	660	625	464.208	131,4	465.208	79,8	470.208	102,5	468.208	60,9
6308	40	90	23	520	800	575	464.308	207,5	465.308	130,7	470.308	174,8	468.308	97,9
16009	45	75	10	330	500	650	464.009	48,9	465.009	33,6	470.009	39,7	468.009	24,4
6009	45	75	16	380	560	650	464.109	74,8	465.109	50,6	470.109	61,4	468.109	37,2
6209	45	85	19	470	720	580	464.209	138,0	465.209	86,3	470.209	117,0	468.209	65,4
6309	45	100	25	540	900	500	464.309	296,4	465.309	177,1	470.309	256,8	468.309	135,5
6010	50	80	16	390	580	600	464.110	82,0	465.110	55,9	470.110	67,0	468.110	40,9
6210	50	90	20	540	770	550	464.210	153,8	465.210	96,5	470.210	130,1	468.210	72,8
6011	55	90	18	400	600	550	464.111	120,8	465.111	80,8	470.111	99,6	468.111	59,6
6012	60	95	18	420	640	500	464.112	127,0	465.112	80,6	470.112	104,3	468.112	61,3

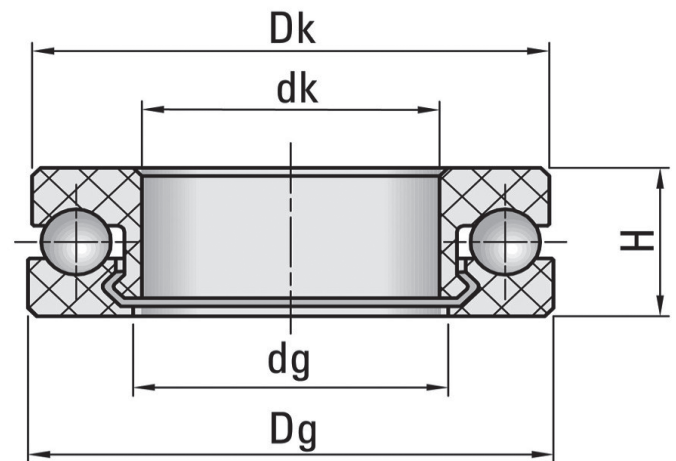

Axial bearing

Plastic axial bearings consist of a shaft and housing washer, as well as corresponding rolling elements. **They're self-retaining.** The locking of the axial bearing serves as a transport and assembly aid. An axial bearing is not suitable for absorbing radial forces.

Their main task is the transmission of axial forces. The transmission can be realized by the contact angle of 90° . The weight/load is evenly distributed over all rolling elements. Axial ball bearings are **ideally suited for low speeds/centrifugal forces**. If requested by the customer, axial bearings can be designed in an oscillating version to compensate for inclined shaft positions of up to 4° .

Axial ball bearings are often used in combination with radial bearings and are also used in a wide variety of applications. SMG has developed an axial radial bearing (ARL) for this.

The standard axial bearings by SMG are designed on the basis of DIN 711, with the exception of edge distance. The axial bearings in our standard portfolio are equipped with an **alternating arrangement of balls, i. e. POM and stainless steel balls**. This results in lower wear and therefore leads to a longer service life.

Standard axial bearings by SMG have the material combinations rings out of POM, balls out of AISI 316 and alternating balls made of POM. (**section Materials, page 6**)



Product table **Axial bearing**

TYPE	dk (mm)	DG (mm)	dg (mm)	Dk (mm)	H (mm)	Basic load rating		max. speed n (rpm)	rings: POM			
						stat (N)	dyn (N)		SMG part no. balls: 1.4401	weight (g)	SMG part no. balls: Glass	weight (g)
51100	10	24	11	23	9	200	250	600	464.500	5,2	465.500	4,0
51200	10	26	11	25	11	210	260	600	464.520	7,9	465.520	6,1
51101	12	26	13	25	9	320	400	540	464.501	5,6	465.501	4,4
51201	12	28	13	27	11	330	410	540	464.521	9,5	465.521	7,2
51102	15	28	16	27	9	500	625	500	464.502	6,1	465.502	4,7
51202	15	32	16	31	12	520	650	500	464.522	11,5	465.522	9,3
51103	17	30	18	29	9	570	710	480	464.503	6,8	465.503	5,2
51203	17	35	18	34	12	600	750	480	464.523	14,9	465.523	10,7
51104	20	35	21	34	10	650	810	460	464.504	10,3	465.504	7,6
51204	20	40	21	39	14	690	860	460	464.524	20,5	465.524	15,7
51105	25	42	26	41	11	710	880	410	464.505	14,6	465.505	11,3
51205	25	47	26	46	15	750	930	400	464.525	26,5	465.525	22,2
51106	30	47	31	46	11	760	950	400	464.506	17,3	465.506	13,4
51206	30	52	31	51	16	820	1.025	375	464.526	34,0	465.526	26,9
51107	35	52	36	51	12	810	1.010	390	464.507	20,8	465.507	16,6
51207	35	62	36	61	18	870	1.090	365	464.527	56,9	465.527	44,3
51108	40	60	41	59	13	890	1.110	375	464.508	31,2	465.508	24,7
51208	40	68	41	67	19	940	1.175	350	464.528	67,1	465.528	53,1
51109	45	65	46	64	14	950	1.185	360	464.509	37,5	465.509	28,2
51209	45	73	46	72	20	1.010	1.260	330	464.529	86,7	465.529	62,1
51110	50	70	51	69	14	1.020	1.275	340	464.510	40,5	465.510	30,5
51210	50	78	51	77	22	1.100	1.375	310	464.530	107,0	465.530	80,4
51111	55	78	56	77	16	1.050	1.310	310	464.511	63,6	465.511	52,1
51112	60	85	61	84	17	1.120	1.400	280	464.512	87,5	465.512	67,9



Pillow blocks and bolt flange housings

Pillow blocks and bolt flange housings are available in various designs.

SMG offers PL pillow block housings, F4-hole bolt flange housings and FL 2-hole bolt flange housings made of plastics.

Pillow blocks and bolt flange housings from SMG are **made of glass-fibre reinforced polyamide**. The screw holes are reinforced with galvanized steel inserts. In addition to the listed plastic insert bearings, lots of conventional steel insert bearings also fit into this housings.



Product table Thermoplastic Pillow Blocks

TYPE	SMG part no.	weight (g)	h (mm)	a (mm)	e (mm)	b (mm)	S ₁ (mm)	S ₂ (mm)	g (mm)	w (mm)
PL 200 - P	874.920	102,8	33,3	126	96	32	12	17,5	16	64
PL 201 - P	874.920	102,8	33,3	126	96	32	12	17,5	16	64
PL 202 - P	874.920	102,8	33,3	126	96	32	12	17,5	16	64
PL 203 - P	874.920	102,8	33,3	126	96	32	12	17,5	16	64
PL 204 - P	874.920	102,8	33,3	126	96	32	12	17,5	16	64
PL 205 - P	874.921	120,1	36,5	134	105	32	12	17,5	16	70,5
PL 206 - P	874.922	190,0	42,9	159	121	40	14,5	21,5	19	82
PL 207 - P	874.923	247,2	47,6	164	126	45	14,5	21,5	19	93
PL 208 - P	874.924	287,3	49,2	176	136	48	14,5	21,5	19	93

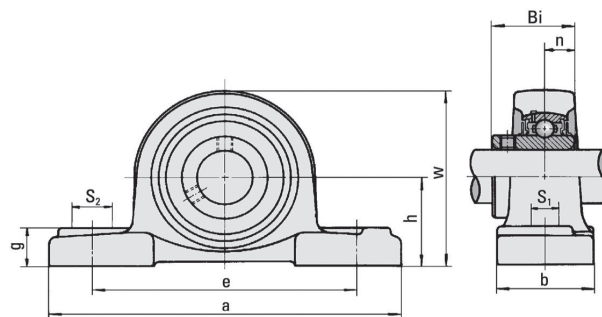

Product table Thermoplastic 4 Bolt Flange Housings

TYPE	SMG part no.	weight (g)	a (mm)	e (mm)	g (mm)	l (mm)	s (mm)
F 200 - P	874.910	115,2	86	63,5	15	30	12
F 201 - P	874.910	115,2	86	63,5	15	30	12
F 202 - P	874.910	115,2	86	63,5	15	30	12
F 203 - P	874.910	115,2	86	63,5	15	30	12
F 204 - P	874.910	115,2	86	63,5	15	30	12
F 205 - P	874.911	138,6	95	70	15	31	12
F 206 - P	874.912	182,5	108	82,5	15,3	33	12
F 207 - P	874.913	235,3	118	92	17	35	14,5
F 208 - P	874.914	294,5	130	101,5	17	39	14,5

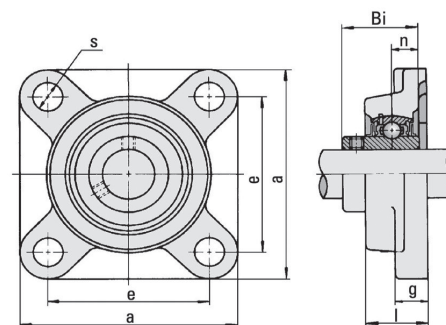

Product table Thermoplastic 2 Bolt Flange Housings

TYPE	SMG part no.	weight (g)	a (mm)	e (mm)	b (mm)	g (mm)	l (mm)	s (mm)
FL 200 - P	874.930	82,3	112	90	60,5	15	29,5	12
FL 201 - P	874.930	82,3	112	90	60,5	15	29,5	12
FL 202 - P	874.930	82,3	112	90	60,5	15	29,5	12
FL 203 - P	874.930	82,3	112	90	60,5	15	29,5	12
FL 204 - P	874.930	82,3	112	90	60,5	15	29,5	12
FL 205 - P	874.931	99,4	124	99	70	15	30	12
FL 206 - P	874.932	143,3	142,5	116,5	83	15	33	12
FL 207 - P	874.933	175,1	156	130	96	17	35	14,5

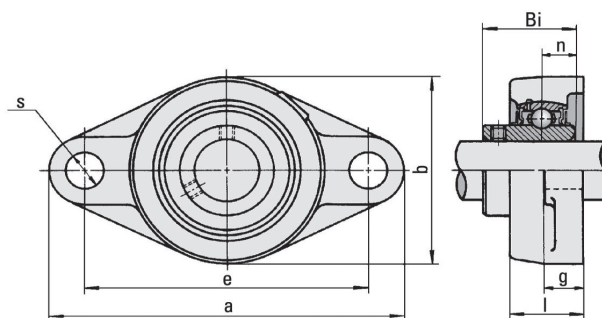

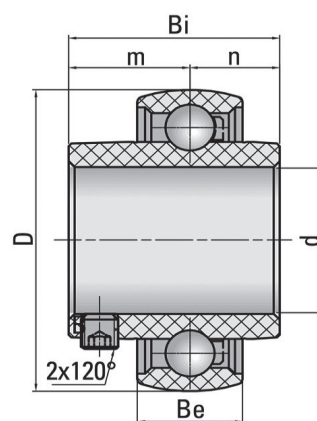

Insert bearings

Insert bearings are single-row, ready-to-assemble units. They consist of a solid outer ring, an inner ring widened on one or both side and a cage. Insert bearings can be designed in such a way that the inner ring is widened on both side, thus reducing the tilting of the inner ring and achieving **a smoother run**.

Insert bearings are used in pillow block and bolt flange housing. They act as **sliding bearings** in the housing, this type of bearing can compensate for misalignment of the shaft. The plastic insert bearings are **maintenance and lubrication-free**.

Insert bearings from SMG fit into SMG's pillow block and bolt flange housing as well as into the well-known, standardized cast steel housings. The standard material combinations for insert bearings are rings made of POM, cage made of PA and balls made of stainless steel AISI 316. (**section Materials, page 6**)

Insert bearings from SMG can also be customized.

Variants in inch dimensions are possible.

Product table insert bearings

TYPE	d (mm)	D (mm)	Bi (mm)	Be (mm)	m (mm)	n (mm)	Basic load rating		max. speed n (rpm)	rings: POM	cage: PA
							stat (N)	dyn (N)		SMG part no. balls: 1.4401	weight (g)
UC 200	10	47	31	17	18,3	12,7	270	420	1.050	464.700	51,8
UC 201	12	47	31	17	18,3	12,7	270	420	1.050	464.701	50,3
UC 202	15	47	31	17	18,3	12,7	270	420	1.050	464.702	47,5
UC 203	17	47	31	17	18,3	12,7	270	420	1.050	464.703	45,9
UC 204	20	47	31	17	18,3	12,7	270	420	1.050	464.704	42,0
UC 205	25	52	34,1	17	19,6	14,5	320	480	950	464.705	51,6
UC 206	30	62	38,1	19	22,2	15,9	360	550	800	464.706	82,7
UC 207	35	72	42,9	20	25,4	17,5	410	620	700	464.707	124,1
UC 208	40	80	49,2	21	30,2	19	440	660	625	464.708	175,1
UC 209	45	85	49,2	22	30,2	19	470	720	580	464.709	197,8

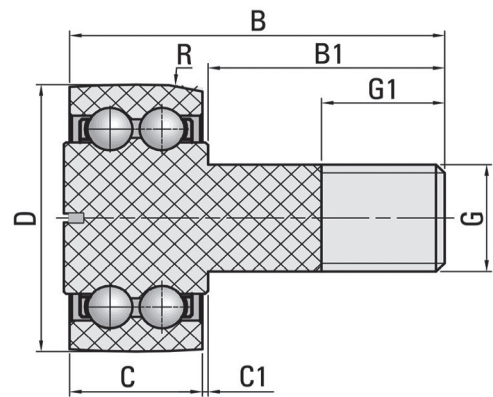
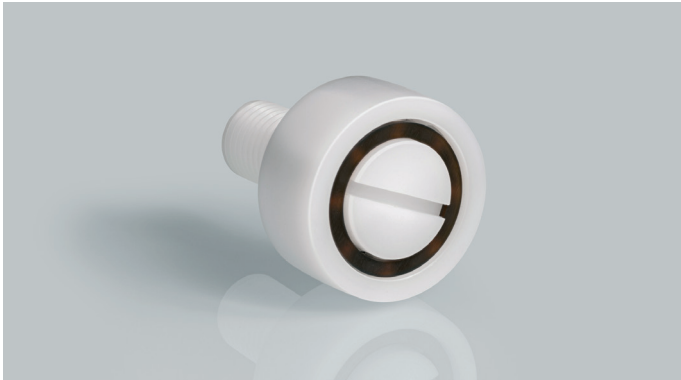

Guide roller

Guide rollers from SMG are 2-row ball bearings with a particularly thick-walled outer ring. The circumferential surface of the outer ring is crowned. Instead of an inner ring, the Cam Follower has a solid roller pin. The pin has a fastening thread and a screw head.

Guide rollers can support high radial forces as well as thrust forces. The thrust forces occurring in the application result from misalignments, skewing or short-term starting shocks.

The advantage of Guide rollers are the **lower Hertzian stress and the lower edge load during tilting**, which reduces the wear of the mating track and thus increases the service life.

The standard material combinations for guide rollers from SMG are rings made of POM, balls made of stainless steel 1.4401 and cages made of PA. ([section Materials, page 6](#))

Guide rollers of SMG can also be customized.

Variants in imperial dimensions are possible.

Product table guide rollers

TYPE	D (mm)	B (mm)	B1 (mm)	G (mm)	G1 (mm)	C (mm)	C1 (mm)	Basic load rating		max. speed n (rpm)	ring: POM	cage: PA
								stat (N)	dyn (N)		SMG part no. balls: 1.4401	weight (g)
KR16	16	27,6	16	M6	8	11	0,6	81	117	2.750	480.416	4,3
KR19	19	31,5	20	M8	10	11	0,5	90	126	2.340	480.419	7,2
KR22	22	36	23,4	M10	12	12	0,6	99	144	1.980	480.422	10,1
KR26	26	36	23,4	M10x1	12	12	0,6	162	234	1.710	480.426	15,0
KR30	30	39,6	25	M12x1,5	13	14	0,6	198	288	1.580	480.430	20,9
KR32	32	39,6	25	M12x1,5	13	14	0,6	198	288	1.580	480.432	23,9
KR35	35	51,3	32,5	M16x1,5	17	18	0,8	306	450	1.260	480.435	40,1
KR40	40	57,25	36,5	M18x1,5	19	20	0,75	396	576	1.122	480.440	55,2
KR47	47	65,3	40,5	M20x1,5	21	24	0,8	486	756	945	480.447	91,5



Ball transfer unit

The central task of the ball transfer unit is the transport function.

The **transport of sensitive surfaces** is easy to realise with cylindrical ball rollers made of plastics.

Ball transfer units can be used in many different ways, whether as roller conveyors integrated in surfaces (ball at top) or as transport rollers integrated in a container (ball at bottom).

Standard POM ball transfer units can be used at temperatures up to 90 °C. At temperatures > 30 °C, the load rating reduction must be observed.

Standard ball transfer units by SMG consist of a POM housing, a ball out of POM or AISI 316, as well as of support balls. ([section Materials, page 6](#))

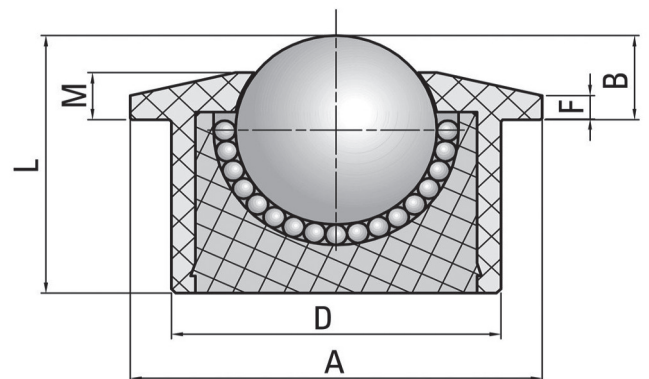

Product table ball transfer unit

TYPE	Ø max. A (mm)	Ø body D (mm)	ball height B (mm)	bundle F (mm)	Lower edge - Upper edge lid M (mm)	Total height L (mm)	Basic load rating stat (N)	rings: POM cage: PA			
								SMG part no. balls: 1.4401	weight (g)	SMG part no. balls: Glass	weight (g)
515	31	24	9,5	2,8	6,3	21	70	467.315	23,2	467415	11,2
522	45	36	9,8	2,8	5,5	30	100	467.322	72,8	467422	35,1
530	55	45	13,8	4	8,3	37	150	467.330	161,7	467430	64,5
545	75	62	19	4	10	53,5	200	467.345	500,9	467445	175,7



The arrangement and load of the ball transfer unit are decisive in the application.

Arrangement

For articles with a uniform, smooth undersurface the distance between the ball transfer units „a“ is calculated by dividing the smallest edge length by 3.

Example:

Undersurface of the conveyed article = 300 x 800 mm

Distance between the ball transfer units:

$a = 300 \text{ mm} / 3 = 100 \text{ mm}$

Load

To determine the load for a ball transfer unit the weight of the conveyed article is divided by the number of the loaded ball transfer units or at least by 9.

Example:

Weight forces = 500 N

Ball transfer unit load (F)

$F = 500 / 9 \approx 56 \text{ N}$ per ball transfer unit

Conveying velocity:

$V_{\text{max.}} = 1 \text{ m/sec.}$



Packaging

Modern warehousing and the **worldwide dispatch** of products place high demands on packaging. The SMIG packaging offers a **perfect protection** for plastic bearings. It is used for **standard products** from our product portfolio.

Advantages

- Proper and dust-protected storage
- Consumer-friendly packaging units (10 pieces for standard bearings – minimum order quantity)
- Clear identification through labelling on the outer packaging

Special plastic bearings are sealed in so-called flat bags in larger quantities and labelled. If required individual packaging is used.

Label on outer packaging

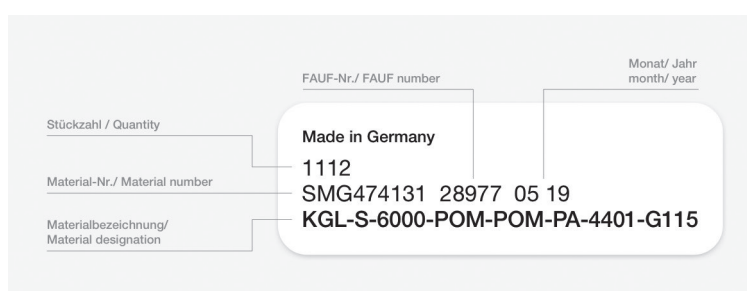

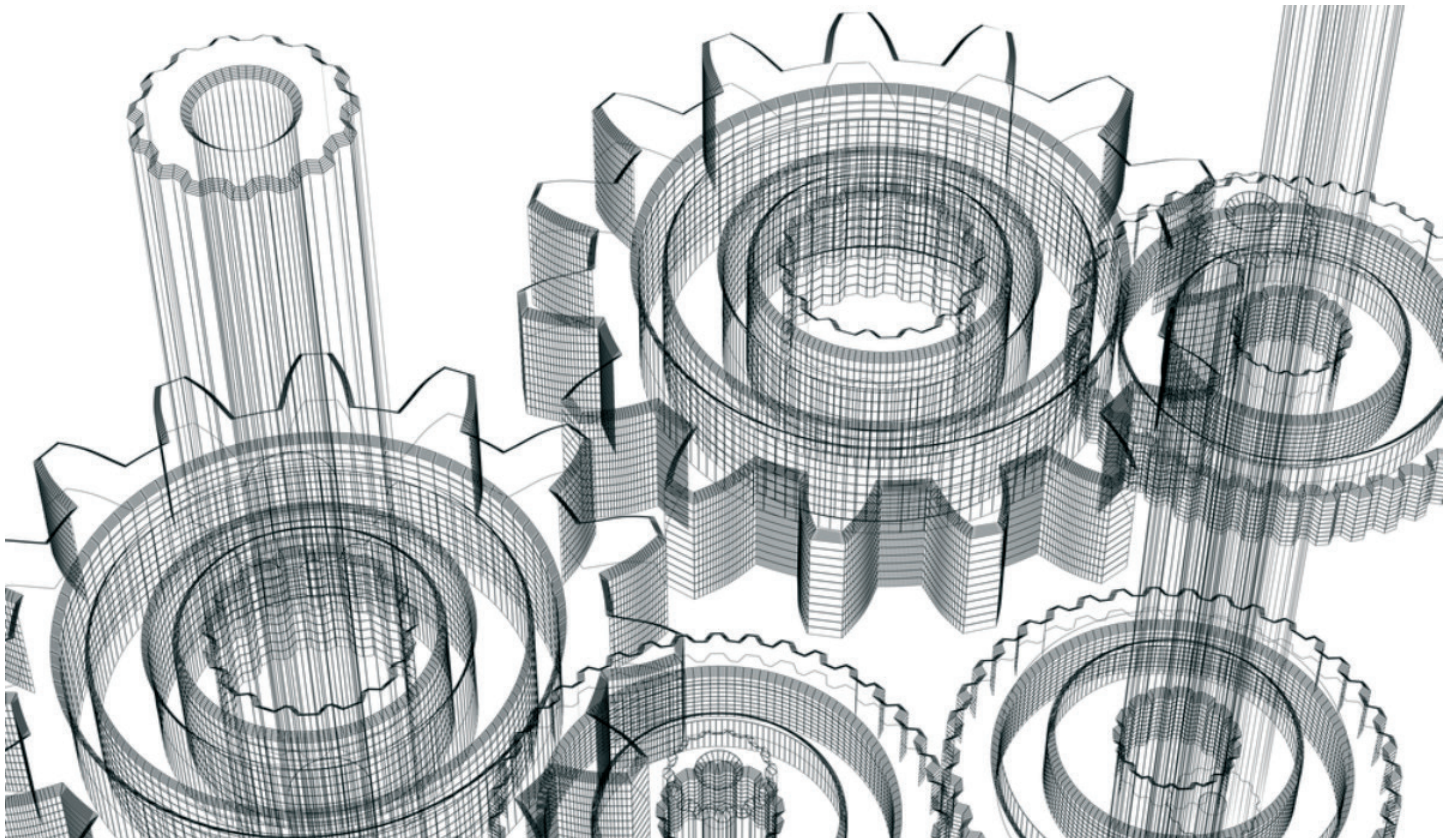

Technical data

Dimensions and tolerances

Fit recommendations

The fit of shaft and housing mainly influence the operating play and therefore the running characteristics. Therefore, we recommend a **tight fit** with a covering-over of around 20 µm either for the shaft or for the housing and a **loose fit** for the other connection side. A tight fit on both sides must be avoided as this would reduce the service life as the bearing clearance would be too small.

Bearing clearance

The radial bearing clearance depends on the **bore diameter** and **material**.

Tolerances

Due to their properties, plastics tend to **dimensional changes**. The **expansion/shrinkage** of the plastic during temperature changes, as well as the **percentage of water absorption** are factors leading to dimensional changes. In the machining production of ball bearing races, **stresses in the semi-finished product** must also be taken into account. Mechanical machining of plastic rods relieves stresses that can lead to the expansion/ shrinkage of the ball bearing races.

Our plastic bearings are designed in accordance with standard DIN ISO 2768 m.

In addition, we use tolerance tables that are based on many years of experience.

Informations about the bearing clearance and tolerances are indicated on our offer drawings.



Load and speed

Static load

The static load indicates the upper limit of the load which the bearing can support at standstill without expecting damage to the raceway and, if applicable, balls.

Dynamic load as a function of speed and operating temperature

The dynamic load is a parameter for the load during operation at which the bearing fulfils its function in the majority of applications.

The dynamic load capacity depends on the operating conditions, such as operating temperature and speed.

Temperature influence

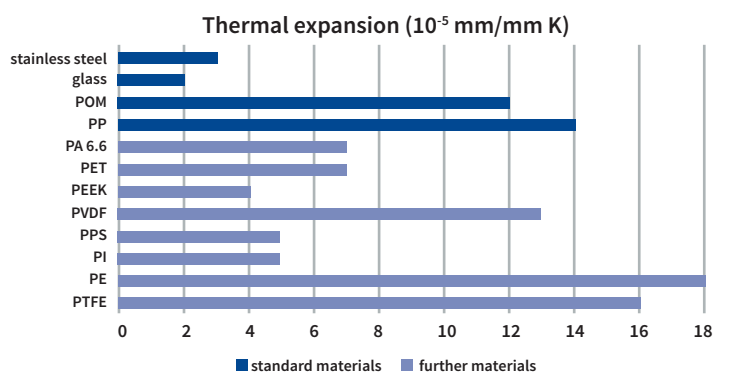
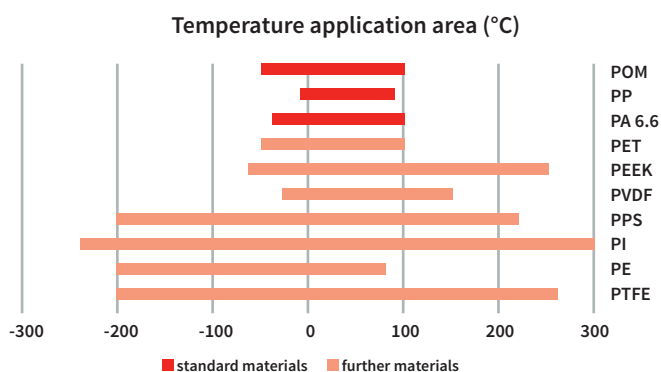
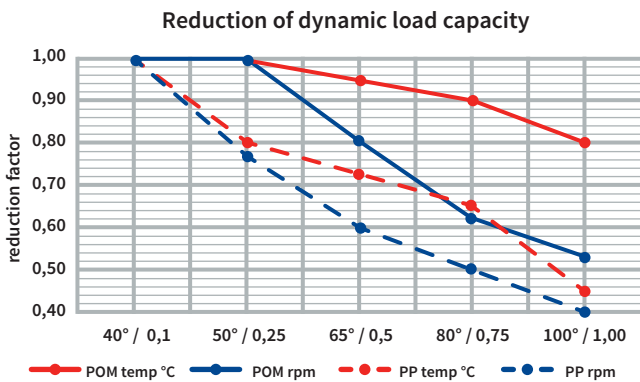



Our Contact

SCHMIING Schmeing GmbH & Co. KG

Ostring 26 · 46348 Raesfeld · Germany

Phone: +49 2865 909 300

Telefax: +49 2865 909 5300

E-mail: sales@smg-plastics.de

Subsidiary company contacts

Spain

Groz-Beckert Iberica S.A.

Riera de San Miguel, 3 Atico 3a
08006 Barcelona, Spain

Herr Jordi Mallol

Phone: +34 93 2187354

Telefax: +34 93 2375679

E-mail: contact_gbib@groz-beckert.com

France

Groz-Beckert France

75007 Paris, France
2, rue de Gribeauval

Herr Sebastien Mauger

Phone: +33 1 45496070

Telefax: +33 1 45446342

E-mail: contact_gbf@groz-beckert.com

Italy

Groz-Beckert Italia S.r.L.

Via Serviliano Lattuada, 12
20135 Milano, Italy

Herr Riccardo La Cara

Phone: +39 02 5467881

Telefax: +39 02 59900547

E-mail: contact_gbi@groz-beckert.com

United Kingdom

Groz-Beckert U.K. Ltd.

139A Gloucester Crescent, Wigston
LE18 4YL Leicester, United Kingdom

Herr Steve Sheffield

Phone: +44 116 2643500

Telefax: +44 116 2643505

E-mail: contact_gbuk@groz-beckert.com

Our traders

USA Monroe Magnus

10625 Texland Boulevard, suite 300
28273 Charlotte, NC

Phone: (877) 628-1613

Telefax: (800) 453-9683

E-mail: sales@askmonroe.com

Website: www.monroeengineering.com

Japan Ever-On Corporation

1-5, 1-CHOME, UESHIO CHUOKU
OSAKA 542-0064

Phone: 81-6-6768-1005

Telefax: 81-6-6764-5539

E-mail: sales@everon.jp

Website: www.everon.jp

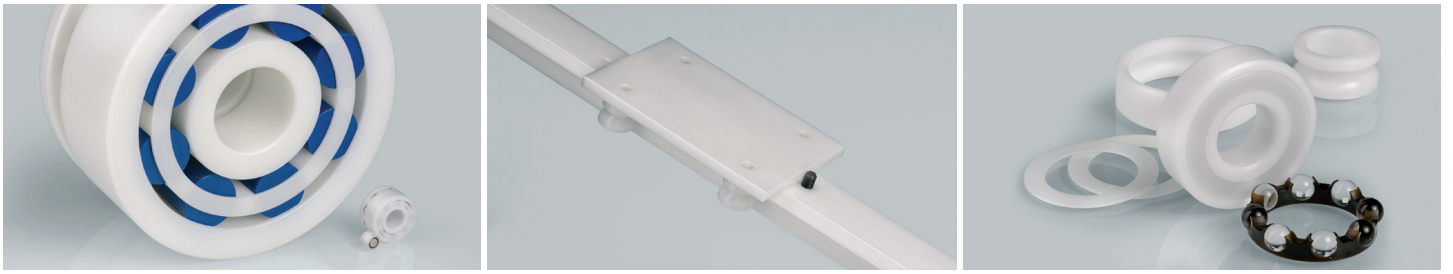

SIMIG[®]
